

Mounting and adjustment instructions for “ELC” type cup dispensers for built in applications.

- 1) Cut mounting hole to appropriate size for dispenser tube. Be sure to allow sufficient distance between holes (see figure 1). “ELC” dispensers can be mounted in any position from vertical to horizontal (see figure 2).
- 2) Set dispenser for proper cup vending as follows:
 - a) Loosen clamping mechanism on dispenser tube.
 - b) Adjust tube diameter so that rim of cup is lightly gripped by indentations on inside of tube (also see instruction label on side of dispenser tube).
 - c) Tighten clamping mechanism on dispenser tube and check fit of cup on inside of dispenser tube.
- 3) Slide tube in to mounting hole until spring clips snap in to place.
- 4) Press optional collar cap over collar ring (if supplied).

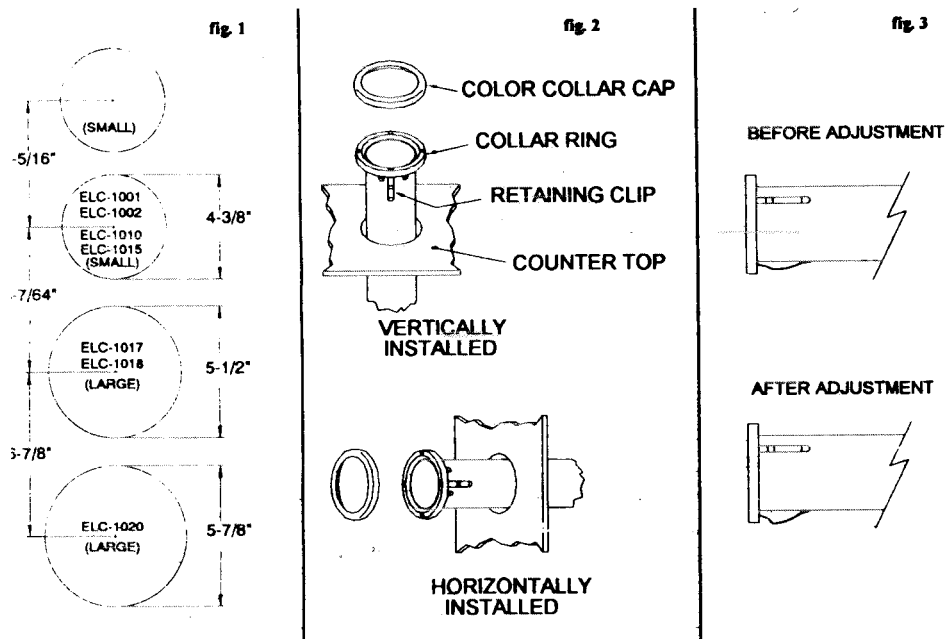

Notes

When installed, the dispenser should be firmly held in the mounting hole by the spring clips. If the dispenser is mounted horizontally, the fit must be tight at the collar and the opposite end of the tube must be supported to prevent damage to the collar assembly.

Do not adjust the tube so tightly around the cups that the dispenser is pulled from the mount when vending.

If the tube fits too loosely in the mounting hole, a tighter fit can be achieved by enlarging the bow in the retaining clip. To enlarge the bow, grasp the clip with needle nose pliers approximately 5/8” below the collar cap. Pull upward while twisting pliers to the right. Adjust all three clips evenly (See figure 3).

“ELC” dispensers are suitable for dishwashing.